

User report

Ventilation/ducting industries



Clinching



Designation	C-shaped stationary machine
Type	DFG 500/150 H in special design
Ident no.	0000086783
Serial no.	900012108
Manufactured	06/2012
Order	584783
Number	1 piece
Other	

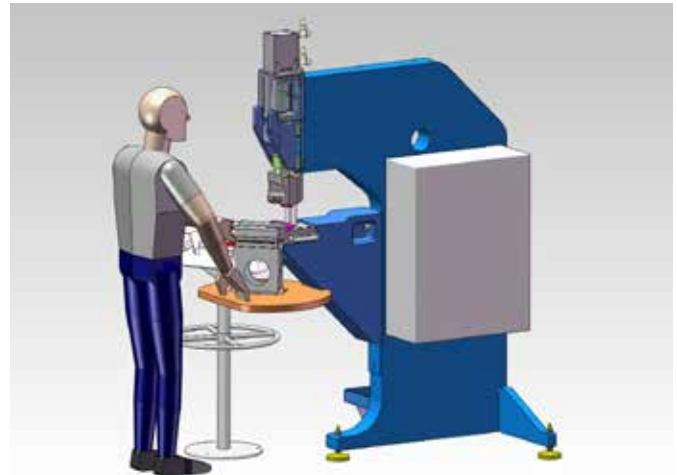

Task:

A new joining method should replace the spot welding process. The challenge was to achieve the retention forces when joining thin into thick layer thicknesses. Furthermore dimensional accuracy and rectangularity were required, concerning narrow workpiece accessibility and variable component sizes as well as ergonomic aspects.

Solution:

In close cooperation with the customer we realized an appropriate solution. The components were adapted by the customer who accepted a solution recommended by ECKOLD. By using special tool holders, including a defined workpiece positioning and four simultaneously working clinching points, the requirements related to the dimensional accuracy and rectangularity were fulfilled.

Customer rating:

- good cooperation on realizing a solution
- reliable machine technology without malfunctions
- reliable technique => additional applications in production
- fast response time in service

DFG 500 150 H



Name	c-shaped stationary machine
Type	DFG 500/150 H in special design
Ident no.	00000086783
Drive	hydraulic
Pressure force	max. 150 kN at 500 bar
Stroke length	100 mm
Connection	400 V / 3 Ph / 50 Hz
Weight	approx. 1400 kg

Opening width	[A] [mm]	91
Throat, horizontal	[B] [mm]	471
Height sheet plane	[J] [mm]	1190
Max. table height	[K] [mm]	890
Width	[X] [mm]	1003
Length	[Y] [mm]	1275
Height	[Z] [mm]	2106

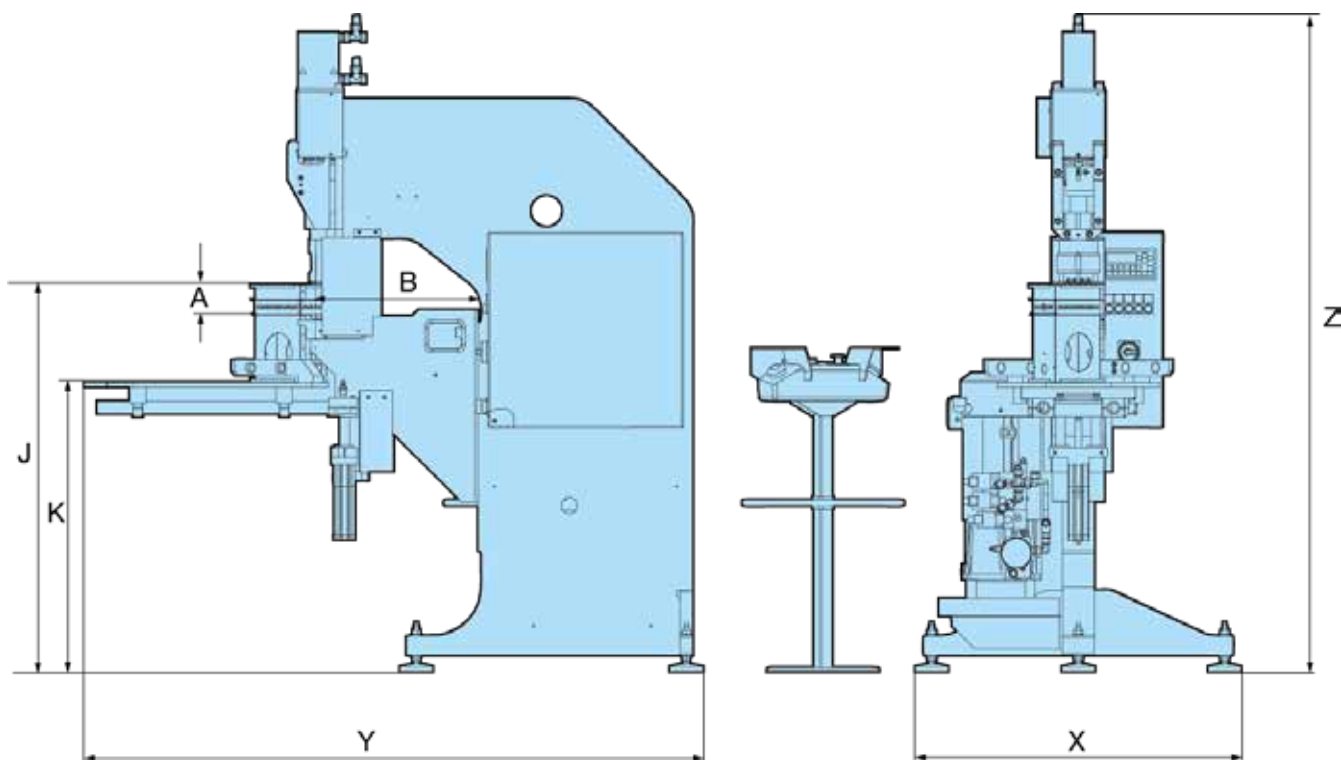

Joining task	1	2
Clinching variant	S-DF 4	S-DF 4
Component	t_1 corpus	corpus
Material	t_1 steel, galvanised	steel, galvanised
Punch-side layer thickness	t_1 0.8 mm	0.8 mm
Intermediate layer	-	-
Component	t_2 central angle	corner angles
Material	t_2 steel, galvanised	steel, galvanised
Die-side layer thickness	t_2 1.25 mm	2.0 mm
Number of clinching points	4/stroke	4/stroke

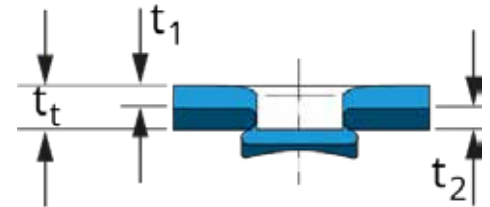

Fire damper

- 1 corpus fire damper
- 2 central angle for wall mounting
- 3 corner angle
- 4 various sizes

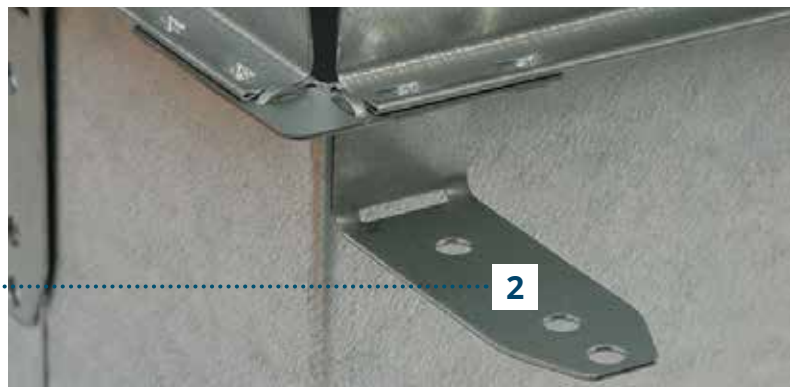

Universal, sturdy machine technology

Choosing from a series of universal c-shaped stationary machines the customized machine is adapted to the individual requirements of our customers and provided with appropriate features.

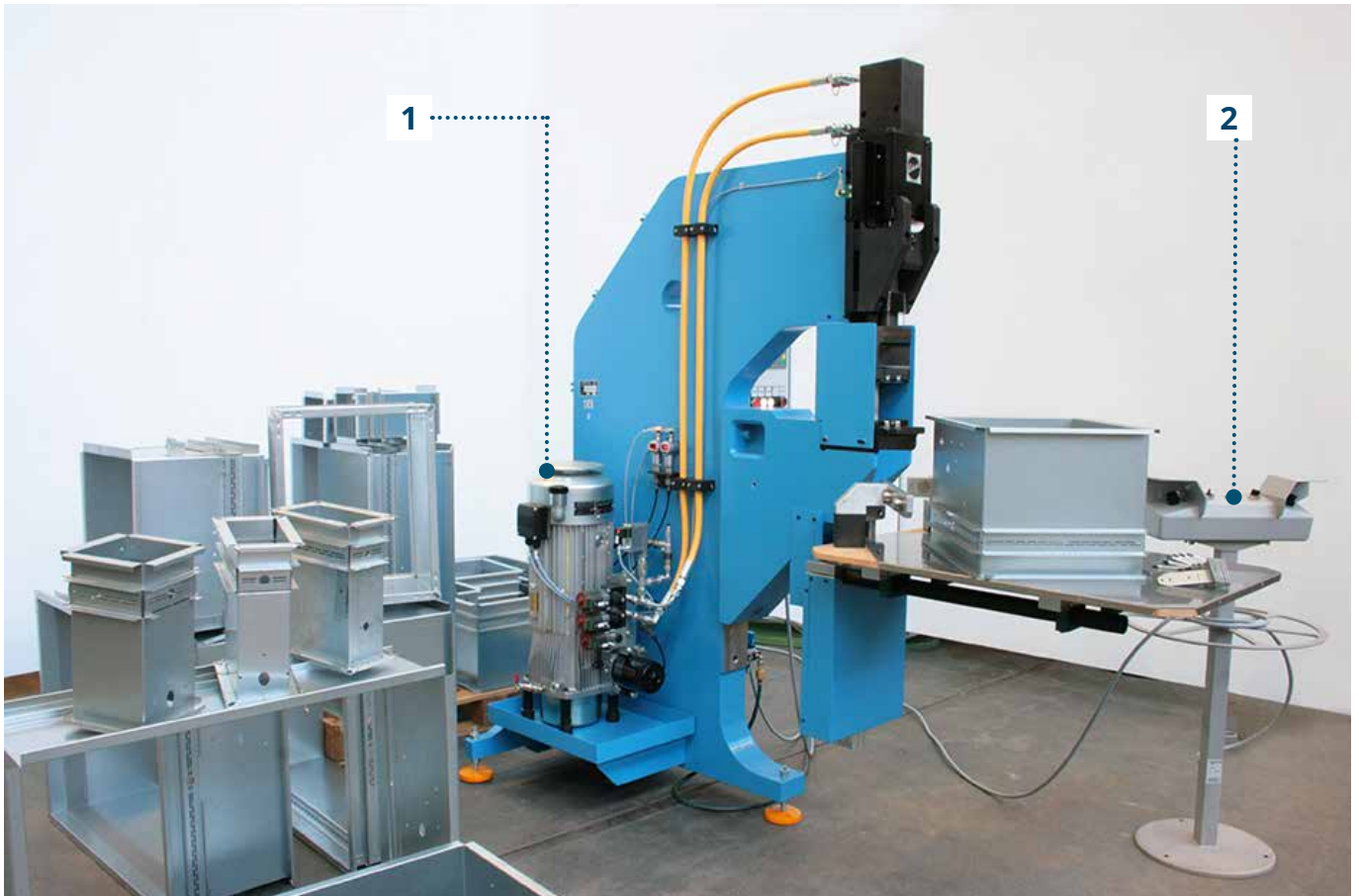

Equipment adjusted to customers' requirements for an optimal series production

Manual work station in consideration of ergonomical requirements and safety aspects.

Features:

- 1 hydraulic drive
- 2 two-hand safety control
- 3 specially adapted tool holders
- 4 height-adjustable table
- 5 adjustable stroke limitation

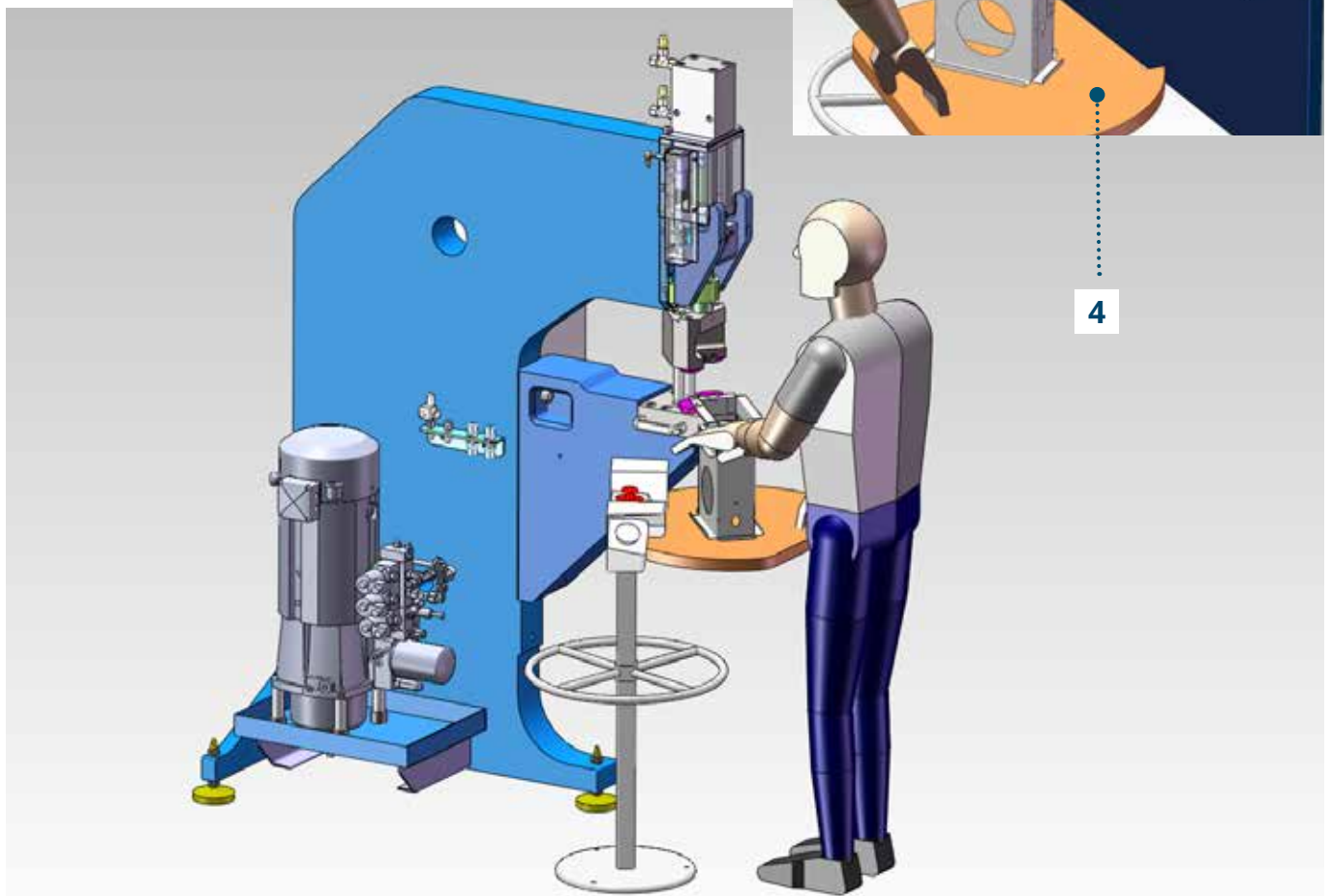
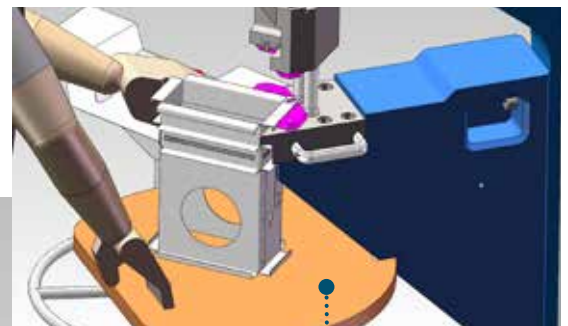
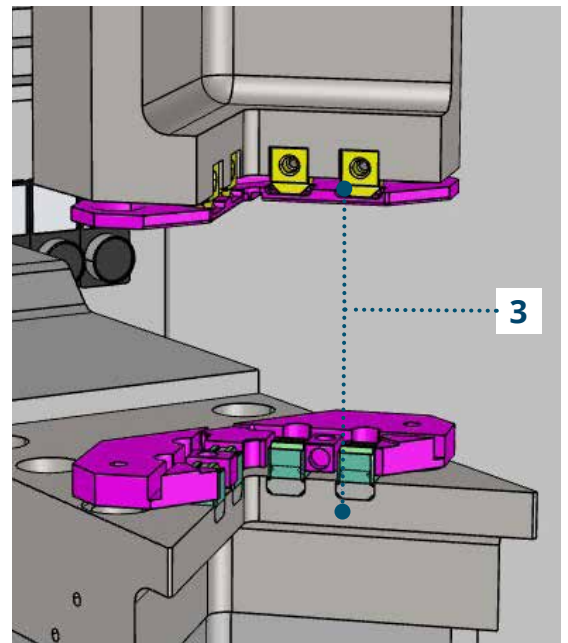

Trading successful for over 85 years

Since our company was established in 1936 by Walter Eckold, the only aspect of our business not to change from that year to this has been our commitment to our customers. Our priority remains to provide our customers with economical and environmentally viable cutting edge technological solutions to their ever changing manufacturing processes.

During our 80 years of trading we have amassed a knowledgeable highly skilled engineering workforce in our specialist areas of shaping and joining sheet metal. These specialist skills enable us to quote from one off standard pieces of equipment to fully tailor-made automated robotic systems. A full range of all our specialist techniques can be found in all sheet metal, craft and industry work-places. Join with us, the successful sheet metal experts, to shape your future metalworking solutions.

Service von A-Z

- Tests and analyses for our customers
- Creation of sample sheets/components
- Preparation of feasibility studies for the design of moulds
- Concept development and constructive realisation of the technical solution
- Production in our own factory
- Commissioning at the customer's premises
- Carrying out regular maintenance
- Support with optimisations in the customer's process
 - Support with the robot position teaching process
 - Creation of micrographs / evaluation of clinching point quality
 - Online support

Start-up support after commissioning up to SOP
Training of system operators/maintenance staff/experts

Data and facts

- Founded in 1936
- Products in use in over 100 countries
- Over 25 sales partners worldwide
- Sales companies in Great Britain, Hungary, USA
- Certified according to ISO 9001:2015
- Certified according to ISO 14001:2015



Eckold technics GmbH & Co. KG

Walter-Eckold-Str. 1
37444 St. Andreasberg
Germany
Tel.: +49 5582 802 0
www.eckold.de
info@eckold.de

Eckold GmbH & Co. KG

Walter-Eckold-Str. 1
37444 St. Andreasberg
Germany
Tel.: +49 5582 802 0
www.eckold.de
info@eckold.de

Eckold Limited

15 Lifford Way
Binley Industrial Estate
Coventry CV3 2RN
Great Britain
Tel.: +44 24 764 555 80
www.eckold.de
sales@eckold.co.uk

Eckold Kft.

Móricz Zsigmond rkp.
1/B. fszt. 13.
9022, Győr
Hungary
Tel.: +36 70 943 311 8
www.eckold.hu
info@eckold.hu

Eckold Corporation

2220 Northmont Park-
way, Suite 250
Duluth GA 30096
USA
Tel.: +1 770 295 0031
www.eckoldcorp.us
info@eckoldcorp.us