



Bördeln
Flanging



Bördeln im Behälter- und Apparatebau

Flanging in tank and vessel building

Die Problematik

Im heutigen Apparate- und Behälterbau werden Umformarbeiten zum Teil immer noch unter Erwärmung der Umformzone und manuell mit dem Hammer ausgeführt.

Nachteil dieser Methode:

- hohe Lärmbelastigung
- gesundheitliche Belastung für den Werker
- hoher Aufwand an Nacharbeit, der sehr kostenintensiv und zeitaufwendig ist

Die Lösung

ECKOLD Mobilformer bringen keinen der genannten Nachteile mit sich. Mobile, freibewegliche Geräte schaffen Flexibilität beim Bördeln, Aushalsen, Richten und Anpassen und sind durch den hydraulischen Antrieb äußerst geräuscharm. Schnell austauschbare Werkzeugeinsätze sichern den universellen Einsatz. Sie werden dem konkreten Bearbeitungsproblem genau angepasst.

Die Anlage

Eine Mobilformer-Anlage besteht aus dem hydraulischen Antriebsaggregat, einer mobilen Zange oder einem Bügel und den Werkzeugeinsätzen. Spielraum schafft eine Reihe von Grundgeräten mit Druckkräften von 50 kN bis 320 kN.

The problem

Forming operations in today's tank and vessel manufacture is still partly done by using heat and hammers on the areas to be formed - especially on large and bulky parts.

Disadvantage of this method:

- high noise level
- dangerous to health
- finishing cumbersome, time consuming and thus expensive

The solution

ECKOLD Mobilformer eliminate the above mentioned problems. These offer flexibility for flanging, neckforming, straightening and correcting. The mobile hydraulic drive considerably reduces the noise level, and by utilising quick change inserts to suit the application in hand, the portable tools are universal and still give excellent results.

The unit

A complete Mobilformer unit consists of portable tool, quick change inserts and hydraulic drive unit. There are several tools available with pressure forces from 50 kN to 320 kN.

Wirtschaftlicher Umformen - flexibel und umweltfreundlich



Zielbranchen / Target sectors



Forming in a more economical way - and without harming to the environment

Die Vorteile

- Flexible Anwendung
- Universeller Einsatz
- Umweltfreundliche Kaltumformung
- Kostengünstige Produktion

The advantages

- Flexible application
- Universal use
- Clean forming without heat
- Production at low cost

Eigenschaften

Es ist Zeit, Hammer und Flamme beiseite zu legen, wenn es um die Randzonenbearbeitung von Behältern, Konen und Böden geht. ECKOLD-Systeme wie die Mobilformer bieten zahlreiche Eigenschaften zur Optimierung im Behälter- und Apparatebau.

Characteristics

It is time to put hammer and flame to rest when working on rim areas of vessels, cones and bottoms. ECKOLD systems like the Mobilformer offer numerous advantages to optimise tank and vessel production.

- Geringe Rüstzeiten
- Geringe Fertigungszeiten
- Mobil mit dem Gerät zum Bauteil
- Vorrichtungsunabhängig
- Baustelleneeignet
- Einmann-Bedienung
- Geräuscharm

- *Min. set-up time*
- *Quick production*
- *Mobile application - move the tool not the workpiece*
- *No fixtures required*
- *Can be used on site*
- *One man operation*
- *Low noise level*



MZ 20



MKF 130



MZ 20



MZ 30

Anwendungsbereiche

Range of application

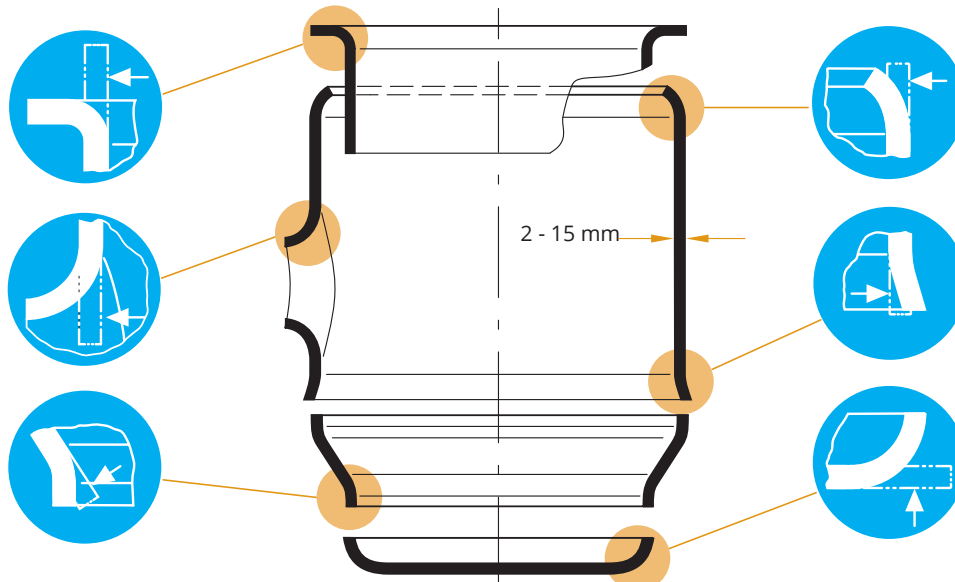

Mobile Zange

Portable pliers

Geeignet zum Bördeln von Zylindern, Böden, Kegeln sowie zum Anpassen. Mit 6 m Hochdruck-Hydraulikschlauch und 2-Hand-Sicherheitsauslösung (ohne Einsätze).

Suitable for flanging cylinders, bottoms and cones as well as for neckforming on manholes and for adjusting and correcting. Complete with 6 m high-pressure hydraulic hose and 2-hand safety release (without inserts).

MZ 20

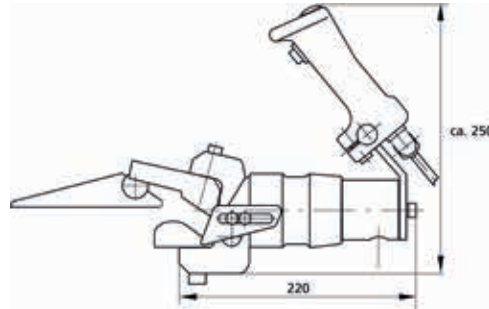
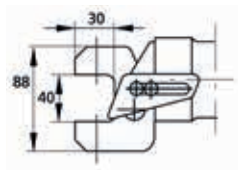

Typ / Type	MZ 20
Ident-Nr.	000 0007 9676
Gewicht / Weight	~ 9 kg
Druckkraft / Pressure force	max. 50 kN
Blechdicke / Sheet thickness:	
St-Qualität / m/s-quality	2.0 - 4.0 mm
Edelstahl / Stainless steel	2.0 - 3.0 mm

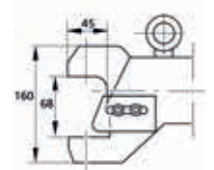
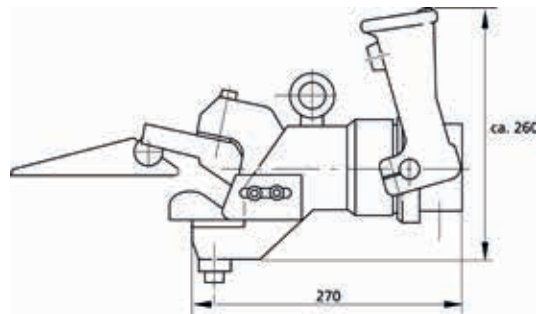

MZ 30



Typ / Type	MZ 30
Ident-Nr.	000 0007 9721
Gewicht / Weight	~ 20 kg
Druckkraft / Pressure force	max. 120 kN
Blechdicke / Sheet thickness:	
St-Qualität / m/s-quality	3.0 - 7.0 mm
Edelstahl / Stainless steel	3.0 - 5.0 mm

Mobiler Kraftformer

Portable Kraftformer

Geeignet zum Bördeln von Zylindern, Böden, Kegeln sowie zum Anpassen. Mit 6 m Hochdruck-Hydraulikschlauch und 2-Hand-Sicherheitsauslösung (ohne Einsätze).

Suitable for flanging cylinders, bottoms and cones as well as for adjusting or correcting. Complete with 6 m high-pressure hydraulic hose and 2-hand safety release (without inserts).

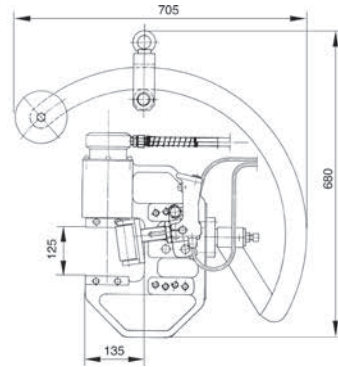
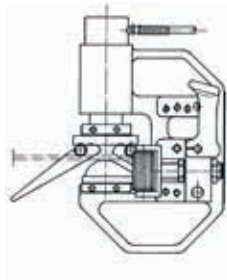

MKF 130/16



Typ / Type	MKF 130/16
Ident-Nr.	000 0008 4444
Gewicht / Weight	~ 80 kg
Druckkraft / Pressure force	max. 160 kN
Blechdicke / Sheet thickness:	
St-Qualität / m/s-quality	4.0 - 10.0 mm
Edelstahl / Stainless steel	4.0 - 8.0 mm

MKF 140/32

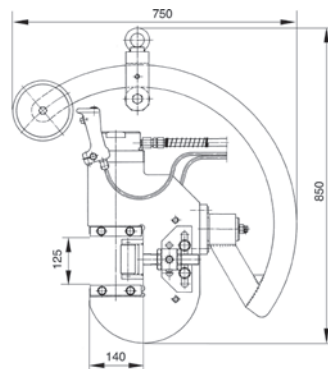

Typ / Type	MKF 140/32
Ident-Nr.	000 0008 2584
Gewicht / Weight	~ 130 kg
Druckkraft / Pressure force	max. 320 kN
Blechdicke / Sheet thickness:	
St-Qualität / m/s-quality	6.0 - 15.0 mm
Edelstahl / Stainless steel	6.0 - 12.0 mm

Bördeleinsätze / Flanging inserts

Auswechselbare Bördeleinsätze zum Bördeln nach innen bzw. außen von Zylindern, Konen, Böden und zum Anpassen, bestehend aus einem Oberteil (1) mit langer, alternativ kurzer Schwenkplatte und einem Unterteil (2).

Interchangeable flanging inserts consisting of top part (1) with long or short swivel plate and bottom part (2), designed for flanging to the inside or outside on cylinders, cones and bottoms and for adjusting work.

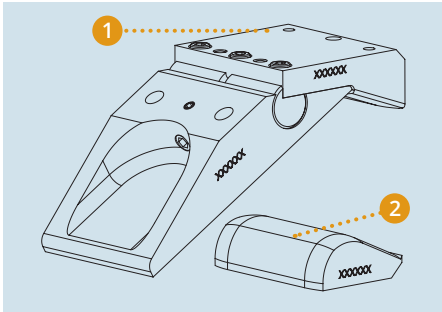

Bördeleinsätze MZ 20, MZ 30
Flanging inserts MZ 20, MZ 30

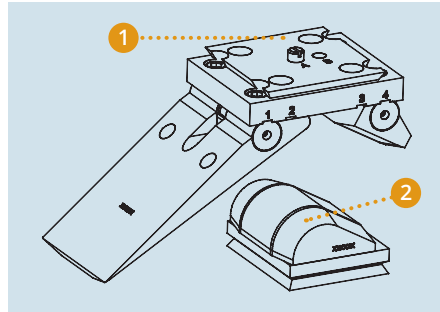

Bördeleinsätze MKF 130/16, MKF 140/32
Flanging inserts MKF 130/16, MKF 140/32

MZ 20
MZ 30
MKF 130/16
MKF 140/32

Bördeln nach innen / Flanging to the inside

Bördeleinsatz- Flanging insert	Ident-Nr. Ident no.	Ø (mm)	R (mm)	H max. (mm)	α	S (mm) Stahl/Steel/ 400 N/mm ²	S (mm) Inox./s.s. 600 N/mm ²
MZ 20	0000 009 6790	500 - ∞	10	15	≤ 80°	2.0 - 4.0	2.0 - 3.0
MZ 20	0000 004 7318	500 - ∞	15	20	≤ 80°	2.0 - 4.0	2.0 - 3.0
MZ 20	0000 001 4699	500 - ∞	20	25	≤ 80°	2.0 - 4.0	2.0 - 3.0
MZ 20	0000 002 6459	500 - ∞	25	25	≤ 80°	2.0 - 4.0	2.0 - 3.0
MZ 30	0000 004 3976	800 - ∞	25	30	≤ 80°	3.0 - 7.0	3.0 - 5.0
MZ 30	0000 002 2906	800 - ∞	30	35	≤ 80°	3.0 - 7.0	3.0 - 5.0
MZ 30	0000 004 7321	800 - ∞	40	35	≤ 70°	3.0 - 7.0	3.0 - 5.0
MKF 130/16	0000 009 6969	1.200 - ∞	30	40	≤ 80°	4.0 - 10.0	4.0 - 8.0
MKF 130/16	0000 009 6970	1.200 - ∞	50	45	≤ 80°	4.0 - 10.0	4.0 - 8.0
MKF 130/16	0000 009 6971	1.200 - ∞	80	45	≤ 45°	4.0 - 10.0	4.0 - 8.0
MKF 140/32	0000 000 9202	1.500 - ∞	50	55	≤ 45°	6.0 - 15.0	6.0 - 12.0
MKF 140/32	0000 002 0155	1.500 - ∞	100	55	≤ 45°	6.0 - 15.0	6.0 - 12.0

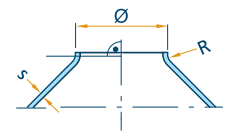
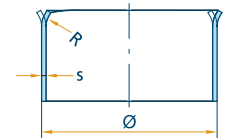
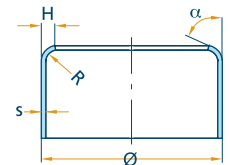

Bördeln nach außen / Flanging to the outside

Bördeleinsatz- Flanging insert	Ident-Nr. Ident no.	Ø (mm)	R (mm)	H max. (mm)	α	S (mm) Stahl/Steel/ 400 N/mm ²	S (mm) Inox./s.s. 600 N/mm ²
MZ 20	0000 005 5173	500 - ∞	15	20	≤ 80°	2.0 - 4.0	2.0 - 3.0
MZ 20	0000 004 7684	500 - ∞	20	25	≤ 80°	2.0 - 4.0	2.0 - 3.0
MZ 30	0000 009 0985	800 - ∞	25	30	≤ 80°	3.0 - 7.0	3.0 - 5.0

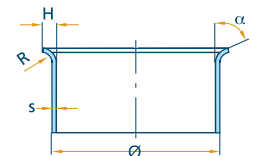

Niederhalter (3) zum Bördeln von Böden, flachen Konen oder Konturblechen

Pressure pad (3) for flanging on bottoms, flat cones or profiled sheets

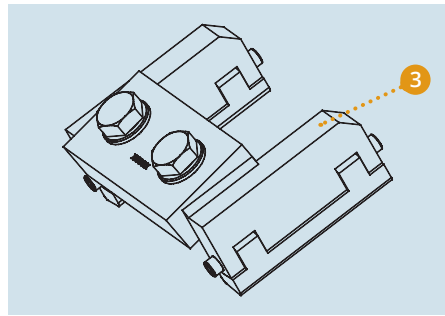
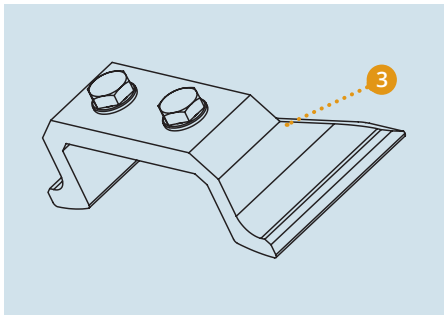

MZ 20
MZ 30
MKF 130/16
MKF 140/32

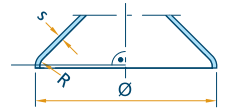

Niederhalter Pressure pad	Ident-Nr. Ident. no.
MZ 20	0000 000 3153
MZ 30	0000 000 2957

Niederhalter Pressure pad	Ident-Nr. Ident. no.
MKF 130/16	0020 302 5102
MKF 140/32	0020 303 5105

Bördeleinsätze / Flanging inserts

Bördeleinsätze für flanschartiges Bördeln nach außen / Flanging inserts for flanging to the outside

MZ 20

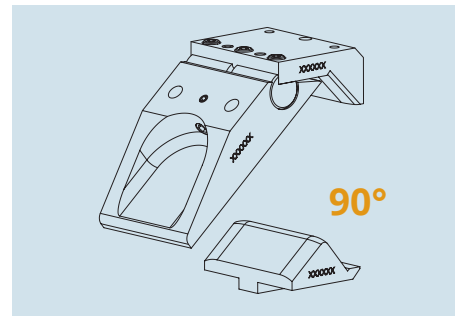
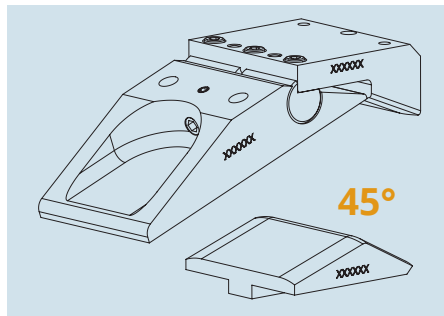
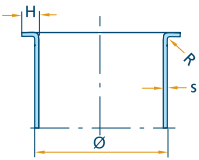

Bördeleinsatz- Flanging insert	Ident-Nr. Ident. no.	Ø (mm)	R (mm)	H max. (mm)
MZ 20 / 45°	0000 008 0677	≤ 500	3	-
MZ 20 / 90°	0000 008 0678	≤ 500	3	25

Bördeleinsätze / Flanging inserts

Bördeleinsätze für das Bördeln (Aushalsen) von Mannlöchern / Flanging inserts for manholes (neck forming)

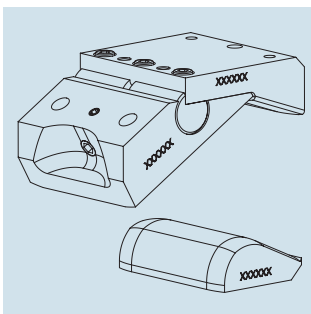

Bördeleinsatz- Flanging insert	Ident-Nr. Ident. no.	Ø (mm)	R (mm)	H max. (mm)
MZ 20	0000 009 6791	500 - ∞	10	15
MZ 20	0000 002 0393	500 - ∞	15	15
MZ 30	0000 008 7789	≥ 400	20	~ 20

MZ 20
MZ 30

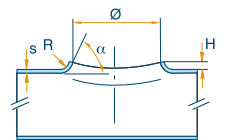
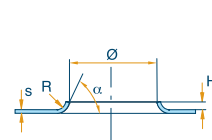

Service von A-Z

- Erstellung von Musterblechen/-bauteilen
- Konzepterstellung sowie konstruktive Umsetzung der technischen Lösung
- Fertigung im eigenen Werk
- Inbetriebnahme beim Kunden
- Durchführung regelmäßiger Wartungen
- Schulungen der Anlagenbediener/Instandhalter/Experten

Daten und Fakten

- Gründung 1936
- Produkte in über 100 Ländern im Einsatz
- Über 25 Vertriebspartner weltweit
- Vertriebsgesellschaften in Großbritannien, Ungarn, USA
- Zertifiziert nach ISO 9001:2015
- Zertifiziert nach ISO 14001:2015

Service von A-Z

- Creation of sample sheets/components
- Concept development and constructive realisation of the technical solution
- Production in our own factory
- Commissioning at the customer's premises
- Carrying out regular maintenance
- Training of system operators/maintenance staff/experts

Data and facts

- Founded in 1936
- Products in use in over 100 countries
- Over 25 sales partners worldwide
- Sales companies in Great Britain, Hungary, USA
- Certified according to ISO 9001:2015
- Certified according to ISO 14001:2015

Eckold technics GmbH & Co. KG

Walter-Eckold-Str. 1
37444 St. Andreasberg
Germany
Tel.: +49 5582 802 0
www.eckold.de
info@eckold.de

Eckold GmbH & Co. KG

Walter-Eckold-Str. 1
37444 St. Andreasberg
Germany
Tel.: +49 5582 802 0
www.eckold.de
info@eckold.de

Eckold Limited

15 Lifford Way
Binley Industrial Estate
Coventry CV3 2RN
Great Britain
Tel.: +44 24 764 555 80
www.eckold.de
sales@eckold.co.uk

Eckold Kft.

Móricz Zsigmond rkp. 1/B. fszt. 13.
9022, Győr
Hungary
Tel.: +36 70 943 311 8
www.eckold.hu
info@eckold.hu

Eckold Corporation

2220 Northmont Parkway, Suite 250
Duluth GA 30096
USA
Tel.: +1 770 295 0031
www.eckoldcorp.us
info@eckoldcorp.us

