



Handzange *Handpliers*

HZ 52

Eine Zange für drei verschiedene Einsatzbereiche
Strecken • Stauchen • Clinchen

One tool for three different applications
Stretching • Shrinking • Clinching

ECKOLD-Handzange HZ 52 für Bleche und Profile

Die ECKOLD-Handzange HZ 52 eignet sich speziell für Anpass- und Korrekturarbeiten auf der Baustelle. Es können Bleche und Profile bis 1,0 mm (St.) oder 1,5 mm (Al) gestreckt, aber auch gestaucht werden. Mit der Handzange HZ 52 können Blechprofile oder Flanschenden durch Stauchen oder Strecken angepasst und korrigiert werden. Auch Clinchen, d. h. Verbinden von Blechen ohne Hilfsmaterialien ist mit der Handzange möglich. Änderungen des Einsatzbereiches einfach durch Werkzeugwechsel.

Hand pliers HZ 52 for sheet metal and profiles

The Eckold hand pliers HZ 52 are specially designed for doing adjustments and corrections at the worksite by stretching and even shrinking. They can handle sheet metal and profiles up to 1.0 mm thickness or aluminium up to 1.5 mm thickness. HZ 52 hand pliers are used for correcting or adjusting metal profiles and sheet flanges by shrinking or stretching to make them fit perfectly. Furthermore, clinching (connecting metal parts without heat or additional fasteners) is possible. Changing of the application just by changing the tools.

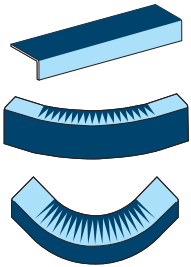

Stauschen / Shrinking

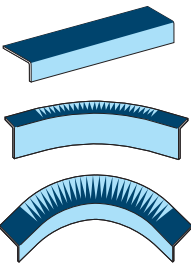

Strecken / Stretching



Ident-Nr. / ID no. 10000029026
Handzange / Hand pliers HZ 52
ohne Werkzeuge / without tools

FWA 40
Formwerkzeug
zum Stauchen
Forming tool
for shrinking
ø 40 mm



Ident-Nr. / ID no. 10000018726 (1 Satz/ 1 set)

FWR 40
Formwerkzeug
zum Strecken
Forming tool
for stretching
ø 40 mm



Ident-Nr. / ID no. 10000018859 (1 Satz/ 1 set)

HLFA 70
Formwerkzeug
zum Stauchen
Forming tool
for shrinking
40 x 70 mm



Mit adhäsiven Kunststoff-Kontaktflächen zum Stauchen ohne Oberflächenbeschädigung, speziell für Leichtmetall.



Ident-Nr. / ID no. 10000002639 (1 Satz/ 1 set)

Equipped with adhesive synthetic working surfaces for shrinking without damaging the surface of the material, especially for light alloys.

HLFR 70
Formwerkzeug
zum Strecken
Forming tool
for stretching
40 x 70 mm



Mit adhäsiven Kunststoff-Kontaktflächen zum Strecken ohne Oberflächenbeschädigung, speziell für Leichtmetall.



Ident-Nr. / ID no. 10000002640 (1 Satz/ 1 set)

Equipped with adhesive synthetic working surfaces for stretching without damaging the surface of the material, especially for light alloys.

DFW-104
Werkzeugträger
zum Clinchen (S-DF)

Gesamtblechdicke
Stahl (400 N/mm²)
Al (250 N/mm²)
max. 2.0 mm

Tool holder
for clinching (S-DF)

Total thickness
mild steel (400 N/mm²)
Al (250 N/mm²)
max. 2.0 mm



Zum unlösbaren Verbinden von Blechen und Profilen aus Stahl oder weicheren Werkstoffen wie Aluminium.

For permanent joining of sheet metal and profiles made of steel or softer materials such as aluminium.



Ident-Nr. / ID no. 00000022218 (1 Satz/ 1 set)

Matrize je nach Blechwerkstoff und Blechdicke auswählen (siehe Tabelle).

Select a die, depending on the material and sheet thickness (see overview below).

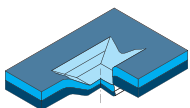

Clinchvariante S-DF 4
Clinging type S-DF 4



SD 701.00 **SMD 721.XX** **SMD 731.XX**
Stempel / Punch **Matrize / Die** **Matrize / Die**
für Stahl/ for steel für / for Al, Cu, Zn



ID-Nr. / ID no.
00403701008



Technische Daten / Technical data

Eckold GmbH & Co. KG

Walter-Eckold-Str. 1
37444 St. Andreasberg
Germany
Tel.: +49 5582 802 0
www.eckold.de
info@eckold.de



Parameter / Parameters	HZ 52
Ausladung vertikal / Throat, vertical	70 mm
Gesamtlänge / Total length	685 mm
Clinchvarianten / Clinching types	S-DF 4
Gesamtfügeteildicke Clinchen / Total thickness	
Stahl / steel ($R_m = 400\text{N/mm}^2$)	max. 2.0 mm
Aluminium ($R_m = 250\text{N/mm}^2$)	max. 2.0 mm
Nettogewicht / Net weight	3.8 kg

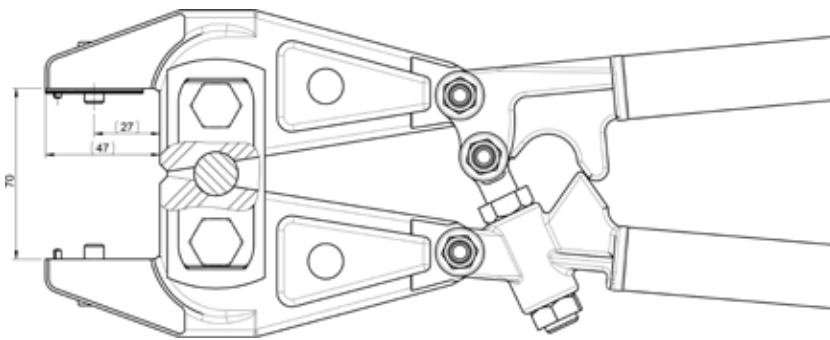

Typ Type	Verwendung Application	Blehdicke Sheet thickness	ID-Nr. ID no.
HZ			10000029026
FWA 40	Stauen / Shrinking	1.0 mm St 1.5 mm Al	10000018726
FWR 40	Strecken / Stretching	1.0 mm St 1.5 mm Al	10000018859
HLFA 70	Stauen / Shrinking	0.7 - 1.5 mm Al, Cu, Zn	10000002639
HLFR 70	Strecken / Stretching	0.7 - 1.5 mm Al, Cu, Zn	10000002640
DFW-104	Clinchen / Clinching	max. 2.0 mm	00000022218
SD 701.00	Stempel / Punch		00403701008
SMD 721.07	Matrize / Die Stahl / Mild steel	0.7 / 0.7 mm	00303721079
SMD 721.10	Matrize / Die Stahl / Mild steel	0.8 / 0.8 mm	00303721102
SMD 721.13	Matrize / Die Stahl / Mild steel	1.0 / 1.0 mm	00303721136
SMD 731.07	Matrize / Die Al, Cu, Zn	0.7 / 0.7 mm	00303731077
SMD 731.10	Matrize / die Al, Cu, Zn	0.8 / 0.8 mm	00303731100
SMD 731.13	Matrize / die Al, Cu, Zn	1.0 / 1.0 mm	00303731139